



Reverse flow injection analysis method for catalytic spectrophotometric determination of iron in estuarine and coastal waters: A comparison with normal flow injection analysis

Yongming Huang, Dongxing Yuan*, Minhan Dai, Yaoxing Liu

State Key Laboratory of Marine Environmental Science, Environmental Science Research Center, Xiamen University, Xiamen 361005, China

ARTICLE INFO

Article history:

Received 27 October 2011

Received in revised form 20 January 2012

Accepted 29 January 2012

Available online 2 February 2012

Keywords:

Reverse flow injection analysis

Catalytic spectrophotometry

Iron

Estuarine and coastal waters

The Pearl River Estuary

ABSTRACT

A method for determining iron in seawater had been developed by coupling reverse flow injection analysis (rFIA) and catalytic spectrophotometric detection with *N,N*-dimethyl-*p*-phenylenediamine dihydrochloride (DPD). With a seawater sample or a standard solution as the carrier, the mixture of DPD and buffer was injected into the carrier stream quantitatively and discretely. After mixing with H_2O_2 , the DPD was oxidized to form two pink semiquinone derivatives that were monitored at 514 nm wavelength with a reference at 700 nm. The method detection limit was 0.40 nmol L^{-1} , lower than half of that of normal flow injection analysis (nFIA) method. The sample throughput was 10 h^{-1} with triplicate determination, compared with 4 h^{-1} for nFIA-DPD method. The analysis results of the certified seawaters CASS-4 ($12.33 \pm 0.18 \text{ nmol L}^{-1}$) and NASS-5 ($3.47 \pm 0.23 \text{ nmol L}^{-1}$) well agreed with the certified values (12.77 ± 1.04 and $3.71 \pm 0.63 \text{ nmol L}^{-1}$, respectively). The typical precision of the method for a 2.97 nmol L^{-1} iron sample was 4.49% ($n=8$). Interferences from copper and salinity were investigated. An instrument was assembled based on the proposed method and applied successfully to analyze total dissolvable iron (TDFe) in surface seawater samples collected from the Pearl River Estuary, the results of which revealed non-conservative behavior of TDFe during the estuarine mixing. Results for these samples with both rFIA-DPD and nFIA-DPD methods showed good agreement with each other. The proposed method was superior to the currently used nFIA-DPD method, particularly when it is adapted for field and in situ deployment, due to its lower reagent consumption, higher sample throughput and keeping the manifold tubing clean.

© 2012 Elsevier B.V. All rights reserved.

1. Introduction

Iron is present at trace level ($<1 \text{ nmol L}^{-1}$) in the surface seawater of open ocean and acts as a limiting factor regulating primary production in high-nutrient, low-chlorophyll (HNLC) regions [1]. The HNLC phenomenon is found not only in open ocean, but also in some of the coastal upwelling regimes [2]. The distribution of iron in estuarine and coastal waters is very complicated and influenced by many factors. The sources of iron to these waters include fluvial input, coastal upwelling and atmospheric deposition. While flocculation and precipitation process scavenge most of the iron transported from rivers, marine organisms also consume significant amount of iron from the seawater [3]. The comprehensive effect of

these factors results in a large iron concentration gradient in estuarine and coastal regimes, from nanomolar to micromolar levels [4,5].

As a worldwide major river system, the Pearl River discharges a great amount of freshwater, nutrients and carbon into the northern South China Sea, leading to eutrophic waters in the Pearl River Estuary and the adjacent coastal area [6]. Deck incubation experiments with this eutrophic estuarine and coastal water have demonstrated that photosynthesis is greatly enhanced by the addition of iron [6]. Nevertheless, data about the concentration and distribution of iron in the Pearl River Estuary and its vicinity are still very limited.

Among the existing techniques for iron determination, graphite furnace atomic absorption spectrometry (GFAAS) was the first one that provided reliable profiles for iron in the ocean [7]. Isotope dilution high-resolution inductively coupled plasma mass spectrometry (ID-HR-ICP-MS) is recognized as the most sensitive, precise and accurate method [8,9]. Yet the cost, size and fragility of GFAAS and ICP-MS prevent them from being used on shipboard. In order to obtain the iron concentration and speciation rapidly, shipboard methods have been developed during the past two decades,

* Corresponding author at: No. 182 (Ocean Building), Daxue Road, Siming District, Xiamen 361005, China. Tel.: +86 592 2184820; fax: +86 592 2183127.

E-mail address: yuandx@xmu.edu.cn (D. Yuan).

and almost all of them are based on flow injection (FI) technique or adsorptive cathodic stripping voltammetry (AdCSV) [4,10–13].

FI application to iron determination is mainly through combining with chemiluminescence (CL) and spectrophotometry detection, either with or without a preconcentration step [13–16]. Although flow injection-chemiluminescence detection (FI-CL) approach is sensitive, robust, and has been well developed by many laboratories [5,17–21], it needs careful pH adjustment to achieve the highest sensitivity and at the same time prevent the occurrence of precipitation [13,19,22], particularly when there is no matrix removal or preconcentration step. Another problem is the variable analytical sensitivity of FI-CL method in analyzing coastal water, which is attributed to the presence of high concentrations of dissolved organic matters (DOM) [23]. Traditional colorimetric FI methods with ferrozine as the spectrophotometric reagent have also been developed for trace iron determination [24,25]. Another spectrophotometry based FI method for iron determination employs the iron catalytic effect on the oxidation of *N,N*-dimethyl-*p*-phenylenediamine dihydrochloride (DPD) with hydrogen peroxide [15,26,27], which has been adapted for in situ measurements in preconcentration mode and direct injection mode [26]. Direct injection mode is sensitive enough for determination of iron in estuarine and coastal waters. Currently, direct injection mode is performed in normal flow injection analysis (nFIA) where sample is injected into the carrier and mixed with reagent streams.

Unlike nFIA, reverse flow injection analysis (rFIA) uses sample as carrier, and reagents are injected into the carrier, thus rFIA consumes less reagents than nFIA and is more suitable for shipboard use and long term observations. rFIA has been used for iron measurement with ferrozine method and proved to be more sensitive than nFIA [24,28]. In order to explore an alternative technique for shipboard monitoring of iron in estuarine and coastal waters, a simple rFIA system has been developed with DPD in this work. The optimal parameters were investigated, and an intercomparison experiment with nFIA-DPD method based on the direct injection mode [15,26] was conducted. One of the primary problems for estuarine and coastal waters analysis is the variation of salinity and the abundance of DOM, both of which may hinder the application of various analytical methods. Thus, the potential effects of salinity and DOM were studied.

Both rFIA-DPD and nFIA-DPD were applied to measuring the total dissolvable iron (TDFe) in estuarine and coastal waters collected from the Pearl River Estuary, and the distribution of TDFe in the surface seawater of this area is reported for the first time.

2. Materials and methods

2.1. Reagents and standards

All reagents and standards were prepared in a Class-100 laminar flow hood using Element-grade purified water ($>18.0\text{ M}\Omega\text{ cm}$) from a Milli-Q water purification system (Millipore). Plasticware for storing reagent solutions and standards as well as seawater samples were Teflon PFA (Nalgene) or low-density polyethylene (LDPE, Nalgene) bottles and washed following the steps described by Achterberg et al. [10]. All chemicals were of commercially available high purity grade and used as received unless stated otherwise. The 0.01 mol L^{-1} *N,N*-dimethyl-*p*-phenylenediamine dihydrochloride (DPD, Fluka) solution was prepared by dissolving 0.2091 g DPD in 100 mL Milli-Q water and 0.2 mL ultrapure hydrochloric acid (Q-HCl, Ultrapur[®], Merck) was added to slow down the oxidation of DPD [27,29]. The DPD solution was prepared daily. Ultrapure acetic acid (Q-HAc) was purified by a double distillation of glacial acetic acid (Suprapur[®], Merck) with a Teflon PFA

sub-boiling still (DST-1000, Saville). Ammonium acetate buffer was prepared by an isopiestic absorbing-reaction (IAR) method. Two 250 mL bottles without caps, one of which contained about 200 mL NH_4OH solution (GR grade, Merck), the other one contained about 120 mL Q-HAc, were placed together in a clean, dry and sealed tank. After two to three days at ambient temperature, with an occasional gentle stirring, crystal of ammonium acetate formed in the wide-mouth bottle where Q-HAc had almost completely reacted. Milli-Q water was added to this bottle to dissolve the crystals and a saturated ammonium acetate solution (pH ~ 5.7) was obtained. 1.5 mol L^{-1} ammonium acetate reaction buffer was prepared by dilution from the saturated ammonium acetate solution and adjusted to pH 6.3 ± 0.2 with Q- NH_4OH , which was obtained via isopiestic distillation from GR grade NH_4OH solution [15]. Triethylenetetramine disulfate salt dihydrate (TETA, Fluka) of 3.8 mg was added into 100 mL reaction buffer (final concentration $100\text{ }\mu\text{mol L}^{-1}$) to eliminate the potential interference of copper. Hydrogen peroxide solution (4.0%, H_2O_2) was prepared by diluting 31% H_2O_2 (Ultrapur[®], Merck) with Milli-Q water. 1 mol L^{-1} Q-HCl solution was prepared for rinsing FIA tubing lines.

Iron and copper standard solutions were made by serial dilution of commercial atomic absorption standards (Certipur[®], Merck) in acidified low iron seawater (LISW, pH 1.7, salinity approx. 34.5), which had been collected from the surface of South China Sea near Southeast-Asian-Time-Series station (SEATS, 18°N , 116°E). The seawater was filtered through a $0.2\text{ }\mu\text{m}$ membrane filter (Millipore) and acidified to pH 1.7, then digested using a UV lamp to breakdown the organic ligands. The acidified and irradiated seawater was adjusted to pH 5.5 with Q- NH_4OH and passed through tandem chelate columns each packed with 10 g iminodiacetate (IDA) chelating resin (Toyopearl AF-Chelate 650M, Tosoh). The effluent was again acidified to pH 1.7 with Q-HCl and used as LISW. The acidified LISW was used for preparing working standard solutions and as the carrier for nFIA-DPD method.

To study the salinity effect on the rFIA-DPD method, acidified LISW (salinity approx. 34.5) was diluted with acidified Milli-Q water to simulate a series of solutions with salinity of 0, 6.9, 13.8, 20.7, 27.6 and 34.5. The solutions were spiked with 0, 11.28, 22.55 and 39.47 nmol L^{-1} iron, respectively, and analyzed with rFIA-DPD method to get a series of matrix spiked curves. The slopes of these curves were used to evaluate the variation of analytical sensitivity with different salinity. Surface open ocean seawater (OSW) and coastal seawater (CSW) collected near SEATS and Jiulong River Estuary (Xiamen western harbor), respectively, were filtered through $0.4\text{ }\mu\text{m}$ pore-size membrane and used for investigation of the DOM effect.

2.2. Apparatus

The schematic diagram of both rFIA-DPD and nFIA-DPD with the flow rates is shown in Fig. 1. Two peristaltic pumps, one 2-channel and the other 4-channel (Baoding Longer Precision Pump Co.), were used to deliver the sample and reagents. A 6-port, 2-position injection valve with a microelectronic actuator (VICI, Valco Instruments Co.) was adopted for injecting buffered DPD in rFIA-DPD, while in nFIA it was for sample introduction. An 8-position selector valve (VICI, Valco Instruments Co.) was used as an autosampler to facilitate sample change and improve sample throughput. A home-made Z type flow cell with 10 mm optical path length was connected to an LS-1-LL tungsten halogen lamp and a miniature multi-channel USB 2000+ spectrophotometer (Ocean Optics Inc.) via two fiber optic cables. All manifold tubing was $1.58\text{ mm o.d.} \times 0.75\text{ mm i.d.}$ transparent FEP tubing (VICI, Valco Instruments Co.) except for the peristaltic pump tubing, where Tygon tubing (Baoding Longer Precision Pump Co.) was used. The cleaning columns, which were used for further purifying the reagents, were constructed from 3.18 mm

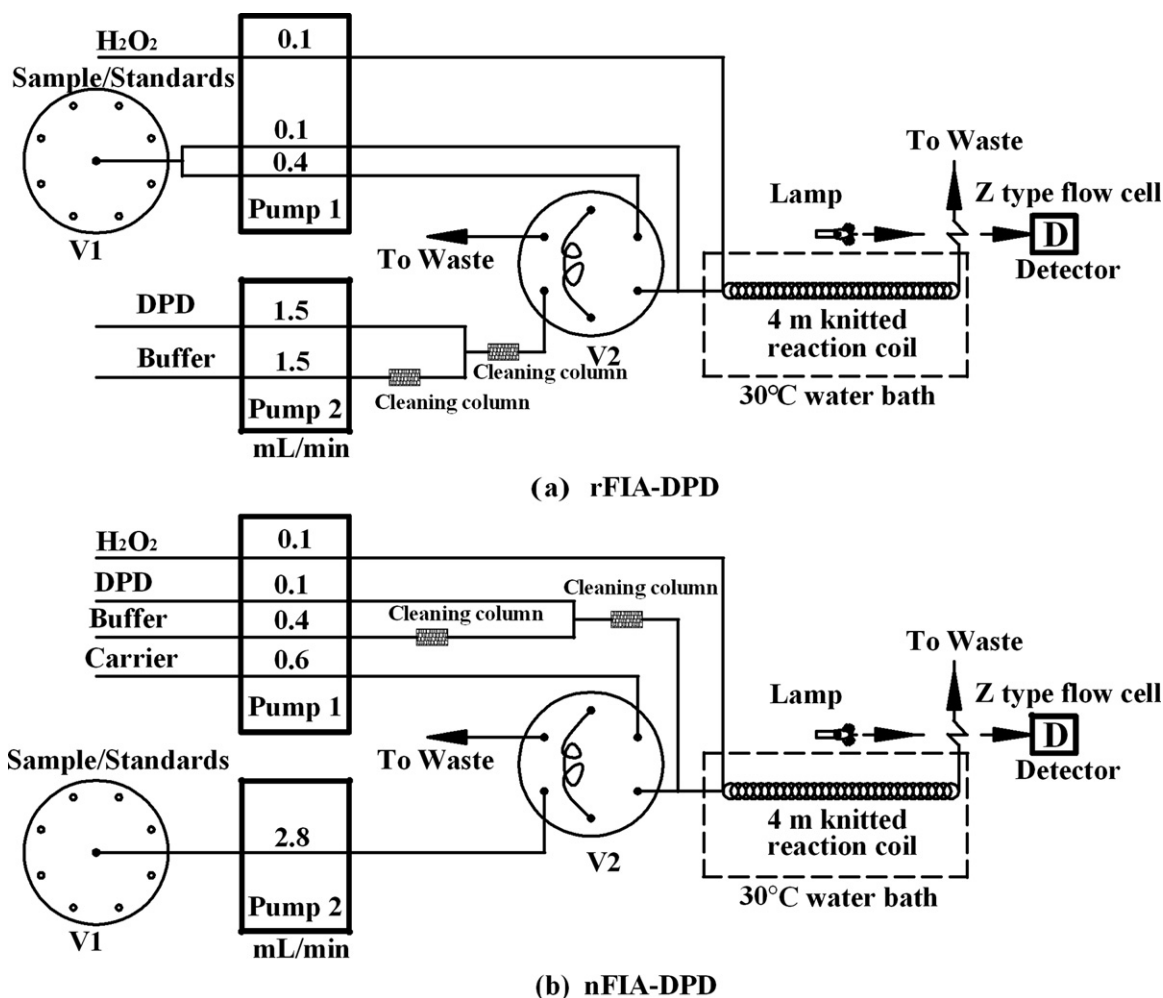

Fig. 1. Flow injection manifold configuration. (a) rFIA-DPD; (b) nFIA-DPD; V1, 8-position selector valve; V2, 6-port, 2-position injection valve.

o.d. x 1.52 mm i.d. FEP tubing and packed with IDA chelating resin. A home-made water bath was used for temperature control.

2.3. Procedures

As shown in Fig. 1a, the carrier was divided into two streams with flow rates of 0.1 and 0.4 mL min⁻¹. DPD and buffer solutions, after passing through the cleaning column and on line mixing, were injected discretely into the carrier stream of 0.4 mL min⁻¹ flow rate via the 6-port injection valve. The carrier pushed the injected reagents and merged with the 0.1 mL min⁻¹ carrier stream and H₂O₂ solution. The pink derivatives produced from the oxidation of DPD were delivered to the Z-type flow cell and detected at 514 nm wavelength with a reference at 700 nm. Contrarily, for nFIA-DPD method (Fig. 1b), sample or standard was injected discretely into the carrier and transported downstream to converge with buffered DPD and H₂O₂.

In rFIA and nFIA systems, Pump 1 ran all the time to push the carrier and reagents solution, whereas the Pump 2 ran only when the buffered DPD/sample was loading into the loop. The whole analysis procedure, including data acquisition, was automated using graphical user software programmed in LabVIEW (National Instruments).

2.4. Sample collection and pretreatment

Estuarine and coastal water samples were collected from the surface of the Pearl River Estuary on-board R/V *Dongfanghong 2* on

6th August 2009, during the summer cruise of the CHOICE-C Project. Fig. 2 shows the study area and the sampling stations, from P1 to P7. All the surface seawater samples were collected with an underway sampling system using an epoxy-coated towed fish (90 cm × 8 cm diameter, 45 kg weight) that was towed at the end of a boom at a distance of 6 m from the side of the ship [30]. Seawater was pumped on-board using a peristaltic pump via an acid-washed Teflon PTFE tubing fitted on the towed fish's nose. The outlet of the sampling tubing was fixed in a Class-100 laminar flow bench with a sink and samples were collected in acid-washed LDPE bottles. As soon as the samples were collected, Q-HCl was added to acidify the samples to pH 1.7. The acidified samples were stored for at least 6 months before determination to allow dissolution of particulate iron, and the determined iron was operationally defined as total dissolvable iron (TDFe) [14,31].

3. Results and discussion

3.1. System design

As shown in Fig. 1a, the rFIA system was deployed with divided streams of carrier (0.1 mL min⁻¹ and 0.4 mL min⁻¹), thus the injected reagents could mix much better with the sample/standard. Compared with sole carrier stream, the double carrier streams allowed adopting a larger injection volume of reagents and the sensitivity was higher by about 10%. On the other hand, the Schlieren effect that resulted from the different refraction between seawater

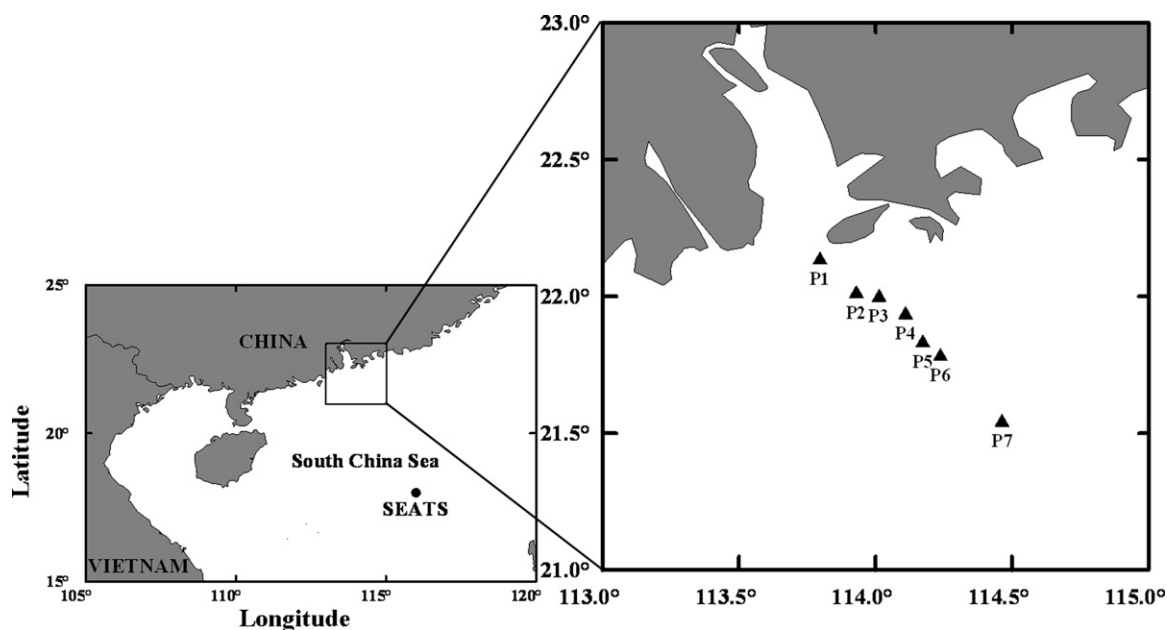

Fig. 2. Map of sampling stations (solid triangle on the right) in the Pearl River Estuary and the adjacent coastal area.

and buffered DPD was minimized with double carrier streams, due to the complete mixing of the carrier stream and injected reagents.

Two peristaltic pumps were used for rFIA-DPD and nFIA-DPD systems. Pump 1 ran all the time and Pump 2 ran only when the mixed reagents/sample was loading into the loop. The same loading time for both systems was 15 s only, thus samples were conserved in the nFIA system, while buffer and DPD were conserved in the rFIA system.

3.2. Optimization of the method variables

In order to maximize the intercomparison, the variables of both rFIA-DPD and nFIA-DPD methods were optimized based on a univariate experimental design. The optimization experiment for rFIA was performed using an acidified LISW (pH ~1.7) spiked with 0 and 20 nmol L⁻¹ Fe(III) as the blank and tested sample, respectively. The samples were served as the carrier. For nFIA, acidified LISW was used as the carrier and the 20 nmol L⁻¹ spiked seawater was the tested sample. The ranges of the variables studied and the relative optimum values are summarized in Table 1.

The optimal pH value for the catalytic oxidation of DPD with iron is between 5.5 and 6.0 [15,32]. However, the buffer concentration should be optimized. In this study, the buffer concentration ranged from 0.29 to 1.9 mol L⁻¹ was studied and 1.5 mol L⁻¹ was selected for rFIA system as a compromise between the blank absorbance and the sensitivity, while 1.9 mol L⁻¹ was used for nFIA system. The effect of the DPD concentration was investigated from 0.003 to 0.06 mol L⁻¹. In rFIA system, the result showed that with the increase of the DPD concentration, the absorbances

of blank and sample increased gradually. But the net absorbance that subtracted the blank absorbance from the sample absorbance increased slightly when the DPD concentration was higher than 0.01 mol L⁻¹. As to the nFIA system, the baseline absorbance increased with increased DPD concentration. Though the baseline could be set to zero electronically, the light that transited to the detector was too weak for detection and might reduce the signal to noise ratio. Moreover, the sample absorbance almost reached a plateau when the DPD concentration was higher than 0.04 mol L⁻¹. H₂O₂ concentration was studied in the range of 1–8%, and the sensitivity of rFIA and nFIA systems plateaued at a concentration of 3.5% and 4.0%, respectively. Consequently, H₂O₂ concentration of 4.0% and 4.5% was used for rFIA and nFIA system in the further study, respectively.

With a fixed length knitted reaction coil (4 m), the reaction time was tested by varying the flow rate of carrier in the range of 0.2–1.4 mL min⁻¹. A flow rate of 0.6 mL min⁻¹ was selected for nFIA, while for rFIA the selected flow rate of 0.5 mL min⁻¹ was divided into two streams with the flow rate of 0.1 and 0.4 mL min⁻¹, respectively, to improve the mixing condition between the injected buffered DPD and the sample. By varying the injection volume from 108 to 720 μL, the highest sensitivity was obtained at 250 and 360 μL for rFIA and nFIA system, respectively. During a previous study, without adopting the double carrier streams in rFIA, double peaks appeared when the injection volume was 150 μL and the signal of the same sample was only about 90% of that with double carrier streams. The effect of temperature on the catalytic reaction has been studied [15,29,32]. The previous problem is the concomitant increase of noise even though a higher signal is obtained with higher temperature [15,32], so that the detection limit cannot be lowered by increasing the temperature. With improved operation, the sensitivity is doubled and a lower detection limit of 0.016 nmol L⁻¹ is achieved [29]. The effect of reaction temperature was studied from 26 to 45 °C in this work. The results demonstrated that the net absorbance increased by about 50% when the temperature increased from 26 to 30 °C, without a detectable increase of noise. When the temperature was higher than 35 °C, the blank absorbance in rFIA and the baseline in nFIA system were both high, resulting in only small net increase for absorbance. The reaction temperature of 30 °C was thus used for both systems.

Table 1
Results of the method variable investigation.

Variable	Range studied	Optimal condition	
		rFIA	nFIA
Buffer concentration (mol L ⁻¹)	0.29–1.9	1.5	1.9
DPD concentration (mol L ⁻¹)	0.003–0.06	0.01	0.04
H ₂ O ₂ concentration (%)	1–8	4.0	4.5
Flow rate of carrier (mL min ⁻¹)	0.2–1.4	0.5	0.6
Injection volume (μL)	108–720	250	360
Reaction temperature (°C)	26–45	30	30

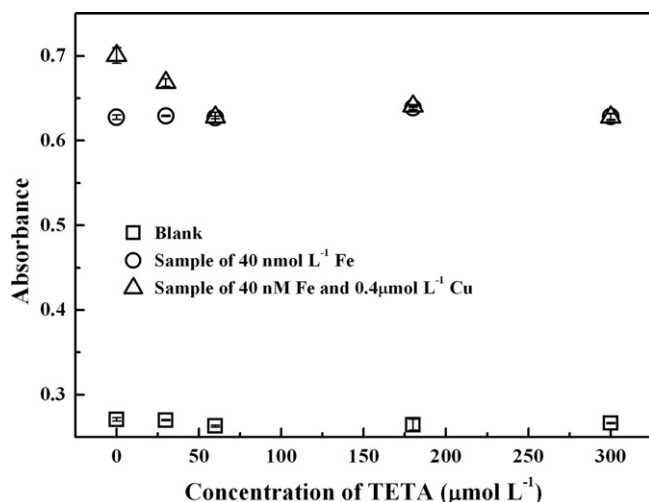

Fig. 3. Effect of TETA concentration on eliminating copper interference. Data points are the mean of triplicate analyses and error bars represent the standard deviation.

3.3. Interferences

The interferences of a series of diverse ions on the determination of iron using DPD method have been investigated previously. The major interference on catalytic oxidation of DPD with iron is from copper, which can be masked with triethylenetetramine (TETA) [15,32]. The concentration of TETA for masking copper was tested by adding various amount of TETA to the reaction buffer. As shown in Fig. 3, with TETA concentration of 60 $\mu\text{mol L}^{-1}$ in the buffer, the interference of copper at up to 10 times the iron concentration could be eliminated. At the same time, the signal of the blank kept nearly constant with increasing TETA concentration up to 300 $\mu\text{mol L}^{-1}$. A TETA concentration of 100 $\mu\text{mol L}^{-1}$ was used for masking copper in samples.

Coastal and estuarine waters are characterized with varying salinity and a high concentration of DOM. It is essential to study the effect of these two factors on the analytical method. The slopes of spiked curves in a series of solutions with gradient salinities (0, 6.9, 13.8, 20.7, 27.6 and 34.5) were obtained and normalized to the slope with salinity of 34.5 to evaluate the variation of analytical sensitivity. As shown in Table 2, the normalized sensitivities were closed to 100% at salinity above 13.8, which meant that the sensitivity of rFIA-DPD method was impervious. When salinity was lower than 13.8, the normalized sensitivities were higher than 100%,

Table 2
Effects of salinity and dissolved organic matters on the sensitivity of rFIA-DPD method.

	Sensitivities normalized to LISW (pH 1.7, 34.5)	Correlation coefficient (R^2 , $n=4$)
Salinity	34.5	100.0%
	27.6	99.6%
	20.7	99.4%
	13.8	100.2%
	6.9	108.3%
	0	158.0%
	OSW ^a	63.1%
CSW ^a	Non-linear relationship	–
OSW-pH 1.7 ^b	99.2%	0.9984
CSW-pH 1.7 ^b	102.8%	0.9967

^a OSW and CSW represent filtered open ocean seawater and coastal seawater, respectively.

^b OSW-pH 1.7 and CSW-pH 1.7 represent filtered open ocean seawater and coastal seawater, both of which were acidified to pH 1.7, respectively.

indicating higher sensitivity. This may result from the larger ionic strength with higher salinity. According to the Arrhenius equation, $k = A e^{-E_a/RT}$, the reaction rate constant k exponentially increases as the activation energy E_a decreases. The reaction rate k in the oxidation of DPD with H_2O_2 is greatly increased by the presence of iron which acts as a catalyst and lowers the activation energy E_a [29,32]. The catalytic effect of iron may depend on its species in the solution. Herein iron mainly existed as ions in the acidified solutions with different salinity, such as $[\text{FeCl}]^{2+}$ and Fe^{3+} [3]. In terms of the Debye-Hückel equation, the activity coefficients of ions in solution decrease with increasing ionic strength. As the sample solutions with salinity increase from 0 to 34.5, the activity of iron may decrease and reach a constant status when the salinity was higher than 13.8 and the activation energy E_a whereby changed. Accordingly, the catalyzed oxidation rate of DPD varied with the salinity and was reflected as the change of the sensitivity.

However, the salinity effect was not observed in nFIA-DPD system, which was in line with previous report [26]. This was due to the difference of carriers in the two systems. The carrier was the major component and contributed mostly to the ionic strength of the reaction solution in FIA system. In rFIA-DPD system, sample solutions were used as the carrier and its ionic strength dominated that of the reaction solution. On the other hand, with the acidified LISW as the carrier in the nFIA-DPD system, the small volume of sample solution injected could mix with the carrier immediately, thus the salinity of the carrier, in which the catalytic reaction happened, changed only a little. Although the sensitivity of rFIA-DPD method varied with salinity, it happened only below 13.8. The salinity in estuarine and coastal waters is usually higher than 13.8, therefore the salinity effect could be neglected in most cases.

The effect of DOM was investigated by comparing the sensitivities in filtered OSW and CSW with that in acidified LISW. As listed in Table 2, the sensitivity in OSW was 63.1% of that in acidified LISW, indicating that 36.9% spiked iron in OSW was inactive for the catalytic oxidation of DPD. Further still, the correlation coefficient R^2 of OSW spiked curve was only 0.6871, suggesting poor reproducibility. With regard to the CSW, a non-linear relationship was observed and the absorbance was nearly identical low and independent of the spiked iron concentrations, showing that the spiked iron was almost completely bound with DOM and the catalytic effect disappeared. The serious DOM complexation effect could be eliminated by acidifying the seawater to pH 1.7 [27]. The normalized sensitivities obtained from OSW and CSW, both were acidified to pH 1.7, were 99.2% and 102.8%, respectively, which approximated that with acidified LISW.

3.4. Method detection limits

The method detection limit (MDL) was estimated according to the method introduced by Berger et al. [33]. Nine aliquots of an acidified LISW sample spiked at 1.80 nmol L^{-1} Fe(III) were determined using rFIA-DPD method. The average concentration measured was 1.91 nmol L^{-1} with standard deviation (SD) of 0.14 nmol L^{-1} . The MDL was calculated via the equation: $\text{MDL} = \text{SD} \times t_{0.02,8} = 0.40 \text{ nmol L}^{-1}$, where $t_{0.02,8}$ was the Student's two-tailed t -statistic at the 98% confidence level with eight degrees of freedom 2.896. The MDL of nFIA-DPD method was also calculated following the same procedure. The spiked concentration was 3.38 nmol L^{-1} , and a MDL of 0.90 nmol L^{-1} was obtained. Five times of the calculated MDL of rFIA-DPD and nFIA-DPD were 2.00 nmol L^{-1} and 4.50 nmol L^{-1} , respectively, both of which were higher than their corresponding spiked concentrations. Therefore, the estimated MDLs for the two methods were valid. At the beginning, lower spiked concentrations had been tested for both methods, but the five times of the calculated MDLs were lower than their corresponding spiked concentrations, which meant the

calculated MDLs were invalid and spiked concentrations should be increased [33]. As described above, only when the spiked concentrations for rFIA-DPD and nFIA-DPD method were elevated to 1.80 nmol L^{-1} and 3.38 nmol L^{-1} , respectively, the calculated MDLs were proved to be valid.

The lower MDL of rFIA-DPD method was attributed to the stable baseline as well as higher sensitivity. It was low enough to allow the application to the determination of iron in estuarine and coastal waters.

3.5. Standard curves and calibration

The upper limits of the linear dynamic ranges for rFIA and nFIA were 230 nmol L^{-1} and 260 nmol L^{-1} , respectively. Typical standard curves were $A = 0.0111[\text{Fe}] + 0.2640$ ($n = 6$, $R^2 = 0.9990$) for rFIA and $A = 0.0082[\text{Fe}] + 0.0016$ ($n = 6$, $R^2 = 0.9988$) for nFIA. The higher slope of the standard curve of rFIA than that of nFIA indicated the higher sensitivity, which may account for the narrower linear range, but lower MDL. Since buffered DPD solution was pumping continuously through the nFIA system and the reagent blank signals were set to zero automatically, only the carrier, LISW, would contribute to the intercept value of the standard curve in nFIA system. Whereas in rFIA system, with sample/standard as the carrier, a colorless mixture of H_2O_2 and carrier flowed through the flow cell continuously and the baseline was set to zero against this colorless solution. When buffered DPD was injected into the carrier, even with trace amount of iron in the sample carrier, absorbance value of about 0.26 was produced, which also contributed to the intercept value of the standard curve in rFIA system. After a long time deployment, it was also observed that the inner of the transparent FEP tubing in the nFIA-DPD manifold was coated with black material, especially at the tubing juncture. This was due to the lengthy contact with the oxidized DPD.

Because of the gradual oxidation of DPD in the solution, both of the two systems were calibrated at the beginning of sample analysis via standard curves. Further still, a three-point calibration, with working standards of iron concentrations 0, 20 and 50 nmol L^{-1} , was performed to ensure the data quality during the sample analysis. The result of diurnal calibration revealed that the variation of the rFIA-DPD curve slope was negligible, while the intercept value gave a standard deviation of 0.0055 ($n = 4$). In addition, a five-day calibration curve study was conducted with three curves performed every day to test the stability. The averaged slope and intercept obtained were 0.0113 ± 0.0012 and 0.2513 ± 0.0978 ($n = 15$), both of which were acceptable but indicated the necessity of periodic calibration.

3.6. Intercomparison and application

The overall comparison of the analytical figures of merit between rFIA-DPD and nFIA-DPD, including the amount of reagents used per sample determined in triplicate, is summarized in Table 3.

Table 3
Comparison of the analytical figures of merit.

	rFIA	nFIA
Method detection limit (MDL, nmol L^{-1})	0.40	0.90
Upper limits of the linear dynamic ranges (nmol L^{-1})	230	260
Slop of standard curve	0.0111	0.0082
Intercept	0.2640	0.0016
Sample throughput (in triplicate, h^{-1})	10	4
The amount of reagents used per sample determined in triplicate	Buffer DPD H_2O_2	6 mL (1.9 mol L^{-1}) 1.5 mL (0.04 mol L^{-1}) 1.5 mL (4.5%)

^a Values in the bracket are the corresponding concentrations used for the determination.

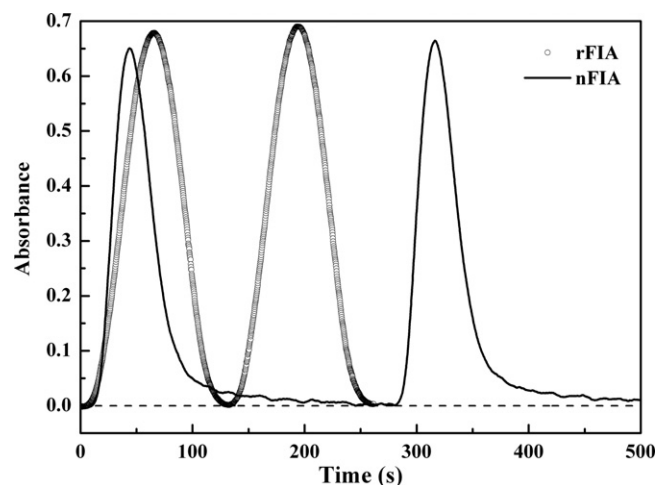

Fig. 4. The typical output signal profile of rFIA-DPD and nFIA-DPD methods.

As shown in Fig. 4, due to serious peak tailing, sample throughput of nFIA-DPD method was lower than the rFIA-DPD method.

The recovery and intercomparison studies of rFIA-DPD and nFIA-DPD methods were performed with coastal seawater samples collected in the Pearl River Estuary. As shown in Table 4, the concentrations determined with the rFIA-DPD method showed no significant difference (*t*-test) with those obtained from nFIA method. The recoveries for both methods were satisfactory, suggesting little matrix influence. The precision of rFIA-DPD method, presented as repeatability, was further tested with sample #1 in Table 4 without spiking with an iron standard, and the result obtained was $2.97 \pm 0.13 \text{ nmol L}^{-1}$ ($n = 8$) with a relative standard deviation (RSD) of 4.49%.

The accuracy of rFIA method was testified by analyzing the seawater certified reference materials (National Research Council, Canada). As shown in Table 5, the results for Coastal Atlantic Surface Seawater (CASS-4) and North Atlantic Surface Seawater (NASS-5) agreed well (*t*-test) with the certified values. Additionally, the nFIA method was used as well for the determination of CASS-4 and NASS-5 and the results showed good agreement with those of rFIA method as well as the certified value.

Both rFIA-DPD and nFIA-DPD methods were applied to analyzing the TDFe in estuarine and coastal water samples collected from the surface of the Pearl River Estuary. The operationally defined TDFe in this work is somewhat uncertain [31], including dissolved iron and some fraction of particulate and intracellular iron that could be dissolved at pH 1.7 within the storage time and catalyze the oxidation of DPD. As shown in Fig. 5a, the concentration of the TDFe fell sharply from about 207 to 1.66 nmol L^{-1} as the salinity rising from 25.78 to 33.92 (in the sequence from P1 to P7). The decrease of TDFe showed a negative deviation from linearity, indicating non-conservative mixing processes, which was somewhat similar to that of dissolved iron [4,5].

Table 4
Recoveries of iron in seawater samples with the proposed method ($n=3$).

Sample	Added concentration (nmol L ⁻¹)	Found concentration (nmol L ⁻¹)		Calculated <i>t</i> -value	Critical <i>t</i> -value (P=0.95)	Recovery (%)	
		rFIA-DPD	nFIA-DPD			rFIA-DPD	nFIA-DPD
1	0	2.98 ± 0.15	3.05 ± 0.17	0.53	2.78	–	–
	3.59	6.39 ± 0.18	6.50 ± 0.26	0.60	2.78	97.30 ± 2.13	97.97 ± 3.07
2	0	20.03 ± 0.32	19.83 ± 0.96	0.34	2.78	–	–
	16.92	35.07 ± 0.62	36.28 ± 0.61	2.41	2.78	94.95 ± 2.39	98.72 ± 0.89

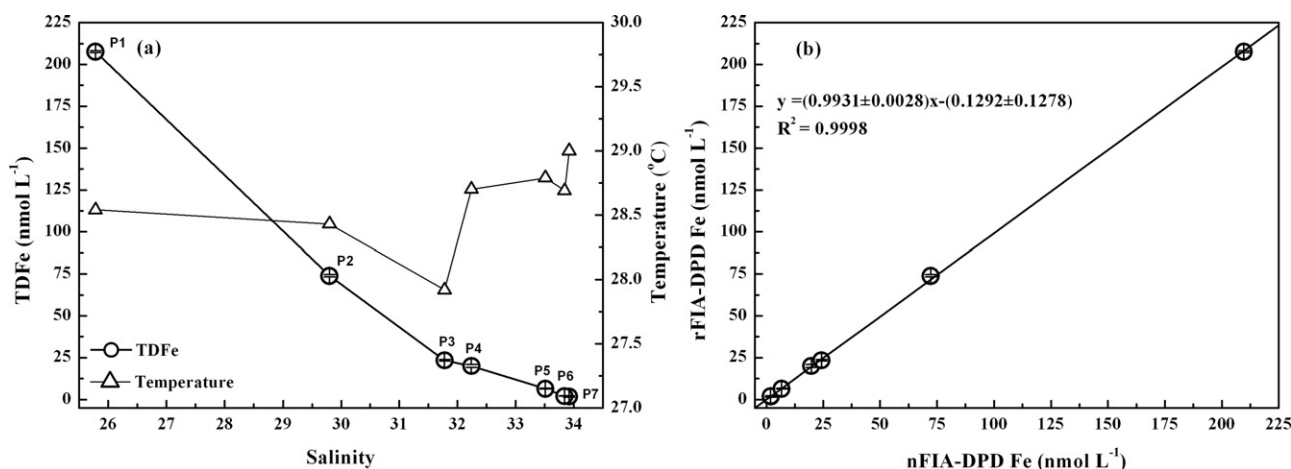

Fig. 5. Total dissolvable iron in the Pearl River Estuary and its adjacent coastal waters (a). Also shown was the comparison of the analytical results between the rFIA-DPD method and nFIA-DPD method (b). Data points are the mean of triplicate analyses whereas error bars represent the standard deviation.

Table 5
Analytical results of CASS-4 and NASS-5 with rFIA and nFIA ($n=3$).

CRM	Certified value (nmol L ⁻¹)	Found concentration (nmol L ⁻¹)	
		rFIA-DPD	nFIA-DPD
CASS-4	12.77 ± 1.04	12.33 ± 0.18	12.16 ± 0.10
NASS-5	3.71 ± 0.63	3.47 ± 0.23	3.95 ± 0.31

As shown in Fig. 5b, the results of the two methods were compared with a plot of rFIA-DPD iron concentration versus nFIA-DPD iron concentration for the samples collected from the Pearl River Estuary. The linear regression equation (with regression coefficient of 0.9998) gave a slope of 0.9931 ± 0.0028 , suggesting good agreement between the two methods. The intercept of -0.1292 ± 0.1278 indicated a small difference for the results between the two methods, i.e., nFIA-DPD was about 0.13 nmol L^{-1} higher than rFIA-DPD. It should be recognized that there was no absolute bias between both methods, especially when taking the analytical uncertainties into account.

4. Conclusions

The proposed method successfully coupled the rFIA to catalytic oxidation of DPD for iron determination in estuarine and coastal waters without matrix separation or a preconcentration step. When the salinity of sample was below 13.8, it was found that the sensitivity of rFIA-DPD method was higher, but stayed constant at salinities higher than 13.8. Considering that the salinity of estuarine and coastal waters is above 13.8 in most cases, the rFIA-DPD method would be considered free of salinity interference. The sensitivity change at lower salinity could be attributed to the variation of ionic strength in the sample solution. Based on this conclusion, it could also be speculated that the higher sensitivity reported by Weeks and Bruland [29] than that reported by Measures et al. [15] may partially due to the use of acidified Milli-Q water as carrier by

Weeks and Bruland [29] rather than acidified LISW by Measures et al. [15].

The superiority of rFIA-DPD to nFIA-DPD was demonstrated, including more stable baseline, higher sensitivity and lower reagent consumption. In particular, the lower reagent consumption means it is more environmental friendly and saves storage space. Thus rFIA-DPD method is more suitable for in-field and in situ application.

Acknowledgments

The authors are particularly grateful to Prof. C.I. Measures at University of Hawaii for his assistance on the setup of the towed fish sampling system and polishing the English of the manuscript. Dr. J. Ma from University of South Florida is also thanked for his comments. Also we would like to thank the crew of the R/V *Dongfanghong 2* for their assistance during the sampling cruise. The work was partly financed by the China National Basic Research Program ("973" Program) "Carbon cycling in China Seas-budget, controls and ocean acidification (CHOICE-C Project, No. 2009CB421200)" and financially supported from the State Key Laboratory of Marine Environmental Science at Xiamen University through MEL funds of MELRI0703.

References

- [1] J.H. Martin, S.E. Fitzwater, *Nature* 331 (1988) 341–343.
- [2] D.A. Hutchins, K.W. Bruland, *Nature* 393 (1998) 561–564.
- [3] S.J. Ussher, E.P. Achterberg, P.J. Worsfold, *Environ. Chem.* 1 (2004) 67–80.
- [4] R.D. Riso, M. Waeles, B. Pernet-Coudrier, P. Le Corre, *Anal. Bioanal. Chem.* 385 (2006) 76–82.
- [5] V. Cannizzaro, A.R. Bowie, A. Sax, E.P. Achterberg, P.J. Worsfold, *Analyst* 125 (2000) 51–57.
- [6] J. Zhang, *Limnol. Oceanogr.* 45 (2000) 1871–1878.
- [7] K.W. Bruland, E.L. Rue, in: D.R. Turner, K.A. Hunter (Eds.), *The Biogeochemistry of Iron in Seawater*, John Wiley & Sons Ltd, Chichester, UK, 2001, pp. 255–289.
- [8] J. de Jong, V. Schoemann, D. Lannuzel, J.L. Tison, N. Mattioli, *Anal. Chim. Acta* 623 (2008) 126–139.
- [9] J.F. Wu, *Mar. Chem.* 103 (2007) 370–381.

- [10] E.P. Achterberg, T.W. Holland, A.R. Bowie, R. Fauzi, C. Mantoura, P.J. Worsfold, *Anal. Chim. Acta* 442 (2001) 1–14.
- [11] A.R. Bowie, E.P. Achterberg, P.L. Croot, H.J.W. de Baar, P. Laan, J.W. Moffett, S. Ussher, P.J. Worsfold, *Mar. Chem.* 98 (2006) 81–99.
- [12] A.R. Bowie, E.P. Achterberg, S. Blain, M. Boye, P.L. Croot, H.J.W. de Baar, P. Laan, G. Sarthou, P.J. Worsfold, *Mar. Chem.* 84 (2003) 19–34.
- [13] S.P. Hansard, W.M. Landing, *Limnol. Oceanogr. Methods* 7 (2009) 222–234.
- [14] A.R. Bowie, P.N. Sedwick, P.J. Worsfold, *Limnol. Oceanogr. Methods* 2 (2004) 42–54.
- [15] C.I. Measures, J. Yuan, J.A. Resing, *Mar. Chem.* 50 (1995) 3–12.
- [16] J. Kozak, N. Jodłowska, M. Kozak, P. Koscielniak, *Anal. Chim. Acta* 702 (2011) 213–217.
- [17] A.R. Bowie, E.P. Achterberg, P.N. Sedwick, S. Ussher, P.J. Worsfold, *Environ. Sci. Technol.* 36 (2002) 4600–4607.
- [18] P.L. Croot, P. Laan, *Anal. Chim. Acta* 466 (2002) 261–273.
- [19] D. Lannuzel, J. de Jong, V. Schoemann, A. Trevena, J.L. Tison, L. Chou, *Anal. Chim. Acta* 556 (2006) 476–483.
- [20] S.J. Ussher, A. Milne, W.M. Landing, K. Attiq-ur-Rehman, M.J.M. Séguret, T. Holland, E.P. Achterberg, A. Nabi, P.J. Worsfold, *Anal. Chim. Acta* 652 (2009) 259–265.
- [21] E. Breitbarth, R.J. Bellerby, C.C. Neill, M.V. Ardelan, M. Meyerhofer, E. Zollner, P.L. Croot, U. Riebesell, *Biogeosciences* 7 (2010) 1065–1073.
- [22] E.G. Roy, M.L. Wells, D.W. King, *Limnol. Oceanogr.* 53 (2008) 89–98.
- [23] A.L. Rose, T.D. Waite, *Anal. Chem.* 73 (2001) 5909–5920.
- [24] Y.M. Huang, D.X. Yuan, J. Ma, M. Zhang, G.H. Chen, *Microchim. Acta* 166 (2009) 221–228.
- [25] J.Z. Zhang, C. Kelbe, F.J. Millero, *Anal. Chim. Acta* 438 (2001) 49–57.
- [26] A. Laes, R. Vuillemin, B. Leilde, G. Sarthou, C. Bournot-Marec, S. Blain, *Mar. Chem.* 97 (2005) 347–356.
- [27] M.C. Lohan, A.M. Aguilar-Islas, K.W. Bruland, *Limnol. Oceanogr. Methods* 4 (2006) 164–171.
- [28] M.I. PascualReguera, I. OrtegaCarmona, A. MolinaDiaz, *Talanta* 44 (1997) 1793–1801.
- [29] D.A. Weeks, K.W. Bruland, *Anal. Chim. Acta* 453 (2002) 21–32.
- [30] S. Vink, E.A. Boyle, C.I. Measures, J. Yuan, *Deep-Sea Res.* 47 (2000) 1141–1156.
- [31] R.T. Powell, D.W. King, W.M. Landing, *Mar. Chem.* 50 (1995) 13–20.
- [32] K. Hirayama, N. Unohara, *Anal. Chem.* 60 (1988) 2573–2577.
- [33] W. Berger, H. McCarty, R.-K. Smith, *Environmental Laboratory Data Evaluation*, Genium Publishing Corporation, Georgia, USA, 1996.